

《Precision Electronic Level》

# Compact Digital Level

## DL-m3

LEVELNIC Owners Manual



Thank you for purchasing Niigata Seiki LEVELNIC.

Please read this manual thoroughly before use to insure proper operation and a long service life.

### [ CONTENTS ]

Introduction	2
Features	2
Part Identification・Function	3
Measurement Range and Zero Point	7
How to Use	9
Zero-Point Setting	11
Leveling a Surface	13
Output Signal	15
Shipping	17
Notices	18
Specifications	19

## [ INTRODUCTION ]

This high precision microcomputer controlled level measures angle by measuring the displacement of a pendulum.

Displacement is converted to an electronic signal and is displayed as mm/m of inclination on the digital display.

## [ FEATURES ]

- ◎ Capacitive sensor for high sensitivity and stable output.
- ◎ Can measure a wide range of slope angles compared to a bubble (or "spirit") level.  
(±5mm/m)
- ◎ Fast response compared to bubble level.  
(Full range response time approx. 10 sec.)
- ◎ Easy to read digital display reduces user fatigue and errors.
- ◎ Reference point easily set using 0-Cal and 1/2-Cal Buttons.
- ◎ RS-232C output signal for connecting to computer or printer.
- ◎ Small and lightweight for easy portability.

[ PART IDENTIFICATION · FUNCTION ]

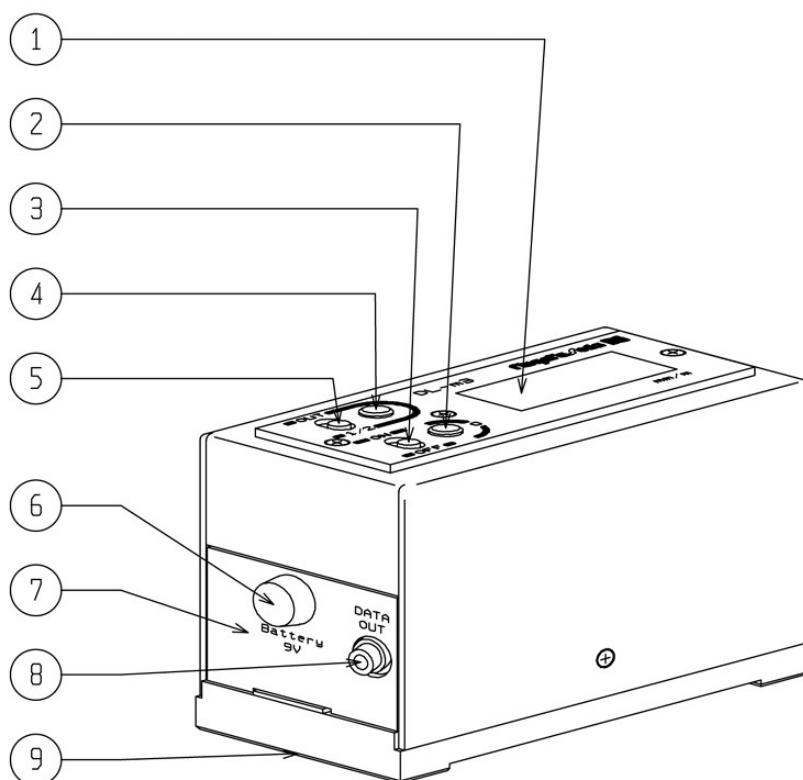

- (1) Display
- (2) 0-Cal Button
- (3) Power Switch
- (4) 1/2-Cal / Output Signal Button
- (5) Function Select Switch
- (6) Battery Cover Screw
- (7) Battery Cover
- (8) Data Out Jack
- (9) Base

## (1) Display

Display shows angle measurements, battery status, and communication status.

### Angle

The angle is displayed in units of mm/m.

If the angle exceeds the measurement range, an error message is displayed.

For a positive out-of-range error, "EEE" is displayed, and for a negative out-of-range error, "–EEE" is shown. The "E" on the elevated side will blink.

When the angle is reduced to within the measurement range, normal operation will continue.

### Battery Status

When Battery level is getting low, the display will blink.

When the display starts to blink please replace the battery with a new one.

### Communication Status

If an error occurs during data transmission, or if cable is not properly connected, an error message (E1, E2) will be displayed for about 3 seconds.

Refer to "Output Signal" section for details.

## (2) 0-Cal Button

0-Cal Button sets the displayed measurement to zero.

Button requires deliberate press of about 1 sec.

(Button can not be used during error display.)

## (3) Power Switch

Gauge is ready for use about 5 sec. after it is switched ON.

0-Cal and 1/2-Cal settings are not stored when power is turned off; when power is turned back on the reference point will need to be reset.

#### (4) 1/2-Cal / Output Signal Button

Button function is set by the Function Select Switch to work as either 1/2-Cal Button, or Output Signal Button.

##### 1/2-Cal Button

Press the 1/2-Cal button to divide the displayed reading by 2.

Value is changed when the 1/2-Cal button is released.

Button requires deliberate press of about 1 sec.

(Button can not be used during error display.)

##### Output Signal Button

Press the Output Signal Button to output data,

When pressed, the instrument transmits the measured data on the RS232C port. Signal output is initiated upon release.

Button requires deliberate press of about 1 sec.

If there is a problem with communication such as the cable not connected, an error message (E1, E2) will be displayed for about 3 sec.

Please refer to "Output Signal" section for details.

#### (5) Function Select Switch

Used to set function of 1/2-Cal / Output Signal Button

"1/2" position sets the function as 1/2-Cal,

"OUT" position sets the function as Output Signal when pressed.

## (6) Battery Cover Screw

When replacing battery, turn counter clockwise to remove.

## (7) Battery Cover

When replacing the cover, make sure the tab is inserted into the slot at the bottom of the compartment.

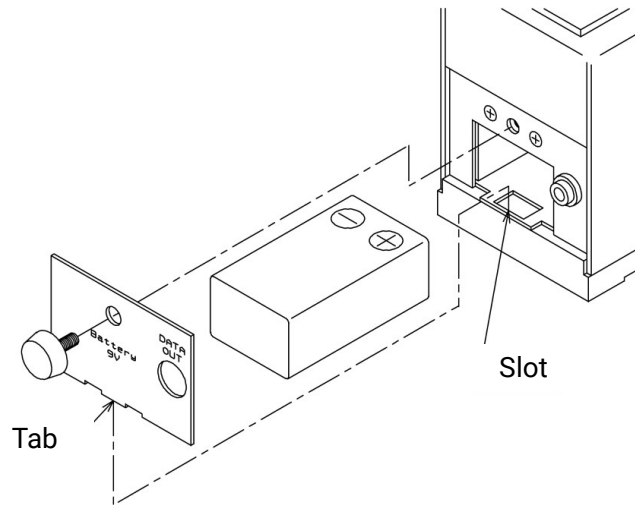

## (8) Data Out Jack

RS-232C port for sending the displayed value and units to a remote device for recording or display.

Signal can be output directly to a computer or printer equipped with an RS-232C port.

Please refer to "Output Signal" section for details.

## (9) Base

The dimension are: Length 100mm, Width 50mm.

## [ Measurement Range and Zero-Point ]

The instrument can be set to display a reference point of "0" at any angle using the 0-Cal and 1/2-Cal buttons.

However, the measuring range of the instrument is limited by the range of the internal variable measured by the device. (This value can be seen when power is first turned ON, before changing the reference point.)

Instrument does not have an internal reference to true horizontal.

The zero reference when power is first turned on does not necessarily show true horizontal.

When an absolute reference to horizontal is needed, the zero-point must be set each time power is turned on.

In this way, the zero-point is accurate with each use with the advantage that any error due to drift in the zero-point is eliminated.

Refer to the section "Zero-Point Setting" below and follow the 0-Cal and 1/2-Cal procedures to set the zero-point.

The measurement range of the instrument is limited by two factors. The sensor operating range for what angles can be detected is  $\pm 8\text{mm/m}$  around its internal zero-point. The range of the display is  $\pm 5\text{mm/m}$ . The instrument measurement range of  $\pm 5\text{mm/m}$  is limited by both these constraints.

The following diagrams represent these two measurement ranges for various conditions. The internal measurement range is shown on the number line at the top of each diagram, and the displayed range shown below.

⊙ Cal, 1/2-Cal operations have not been performed.

(Zero reference point for displayed value is same as internal reference.)

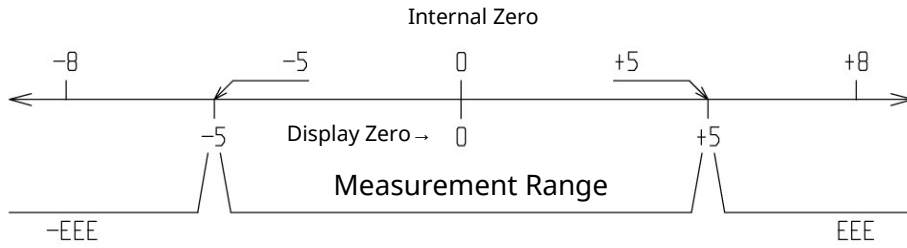

⊙ Reference point moved 1 mm/m using the 0-Cal, 1/2-Cal operations.

(For example, initial reading was 1 mm/m when 0-Cal is performed, or 2 mm/m before 1/2-Cal is performed.)

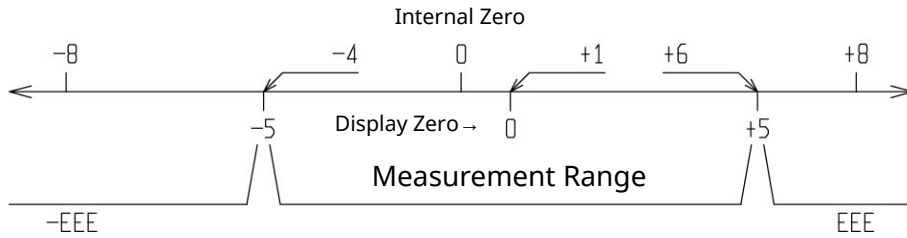

⊙ Reference point moved 3.4 mm/m using the 0-Cal, 1/2-Cal operations.

(For example, initial reading was 3.4 mm/m when 0-Cal is performed.)

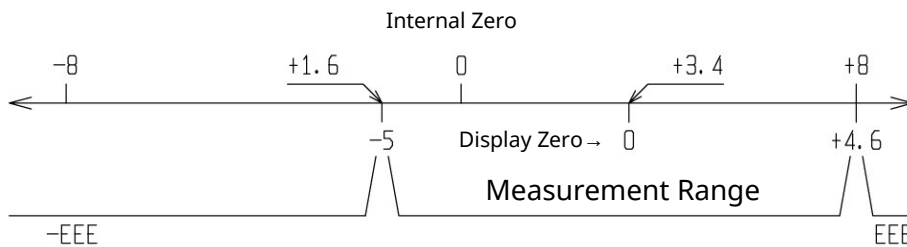



## [ HOW TO USE ]

This is a precision instrument. Please handle with care and avoid any shock or mishandling.

Before use, wipe the instrument base and the surface to be measured using a soft cloth or lens cloth moistened with mineral spirits or alcohol to remove any grease and contamination.

Place the instrument on the surface to be measured.

Turn on the instrument using the Power Switch.

For best results, wait about 10 min. after power on for internal circuitry to stabilize.

The zero-point will shift up to 0.02mm/m when first turned on as the system warms up. If this level of precision is not needed you can begin measurements as soon as it is turned on.

Make sure there is no difference in temperature between the instrument and the surface to be measured.

When the instrument is moved from a warm location to cold, (or visa versa) the display reading will not be stable. Please allow time for display to stabilize before taking measurements, or place the instrument where it will be used an hour in advance.

After use, protect the base of the instrument by coating with rust-preventive oil before storage.

When viewed from the front (with the display on the right side,) if the right side is elevated the angle reading will be an increasing positive number.

If the angle is out of range an error message will be displayed. For negative angles, a "-" sign is also shown. In the error message, the "E" on the elevated side will also blink to indicate the direction of the out-of-range error.

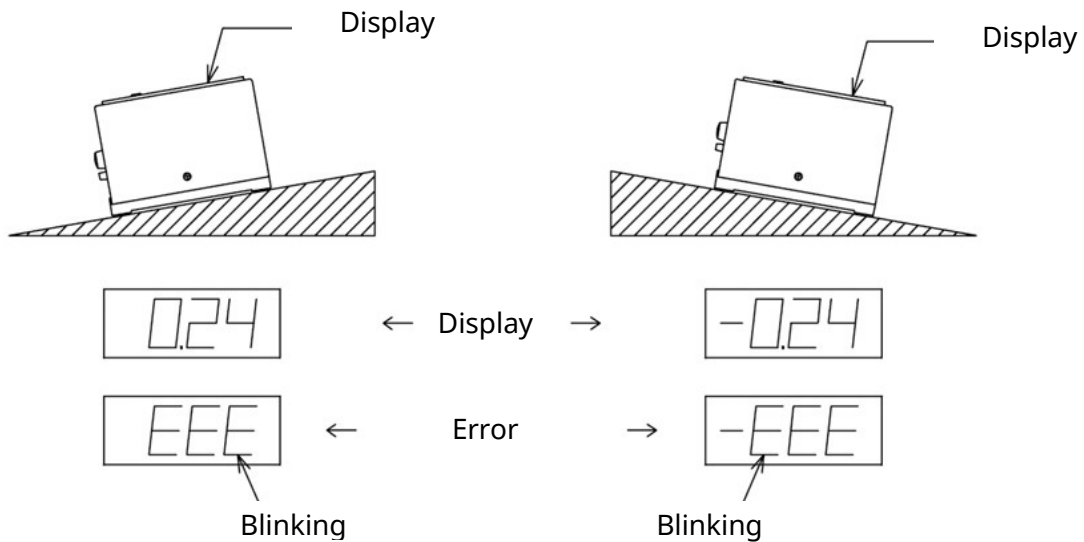

The gauge will display the angle of inclination as mm/m, which is the elevation for the surface over a distance of 1 meter.

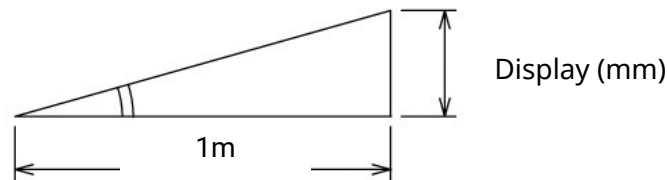

The actual height difference over a specified distance or pitch can be calculated as follows:

$$\text{Height Difference / Pitch} = \text{Reading} \times \frac{\text{Pitch}}{1000} \quad [\text{mm}]$$

For the example with the measurement pitch = 100mm,

$$\begin{aligned} \text{Height Difference / Pitch} &= \text{Reading} \times \frac{100}{1000} \quad [\text{mm}] \\ &= \text{Reading} \times 0.1 \quad [\text{mm}] \end{aligned}$$

## [ ZERO-POINT SETTING ]

The instrument does not have a preset absolute zero-point.

When first turned on, a reading of zero ( the internal value ) will not necessarily indicate that the gauge is at true horizontal position. If a zero-point is required it must be set each time the instrument is switched on.

In this way, calibration error is eliminated and the zero-point is set accurately each time.

Setting the zero-point to true horizontal is accomplished using the 0-Cal and 1/2-Cal Operations.

A) For comparing relative slope of different surfaces.

(1) Place the instrument on the surface to be used as the reference.

(2) When the display has settled, press the 0-Cal Button to set the display to zero.

A relative zero-point has now been set for use in comparative angle measurements.

B) If there is a true horizontal reference surface available.

(1) Place the instrument on the surface to be used as the reference.

(2) When the display has settled, press the 0-Cal Button to set the display to zero.

Zero-point has now been set for absolute measurements.

C) If surface is not known to be level.

(1) Place the instrument on the surface to be used as the reference.

(2) When the display has settled, press the 0-Cal Button to set the display to zero.

(3) Rotate the instrument 180° in the same spot on the surface.

(4) When the display has settled, press the 1/2-Cal Button to divide the display reading by 1/2 .

Zero-point is now set at true horizontal.

The display will show the absolute tilt of the surface the instrument is on.

Once this operation is done, the zero-point is set. However in case (C), if the reference surface is not level in the roll direction (perpendicular to the measurement axis,) there is a possibility of introducing some error to the measurement so make sure the surface is first leveled to reduce roll.

« 0-Cal, 1/2-Cal Operation »

The zero-point reference is set without an absolute reference by using the direction of Earth's gravity as a reference. This can be understood from the following procedure.

Suppose a slope having an angle  $\theta$  with respect to the horizontal plane.

Place on that slope a board with a weight suspended on thread.

As seen in the diagram below, the weight will move toward side A of the board at an angle  $\theta$  from the line perpendicular to the slope.

When the board is turned  $180^\circ$ , the weight now moves toward side B of the board by angle  $\theta$  from the line perpendicular to the slope.

Using this method, even without a true horizontal reference, we can determine the value of the angle  $2 \times \theta$ , where  $\theta$  is the angle of the slope in reference to the horizon.

By dividing by two, we can determine  $\theta$ , the tilt of the slope.

If the gauge is set to zero on a slope, then when the gauge is rotated  $180^\circ$  it will show the angle twice the actual tilt of the slope.

If the reading is then halved, it will show the tilt of the slope, and by adjusting the slope until that reading is zero, we can adjust the surface to horizontal.

Using this method for setting the horizontal reference, the reference set is always accurate and the gauge reliable. For an instrument with built in reference, there is a chance that it will be inaccurate and yet will continue to be used without knowing of the deviation.

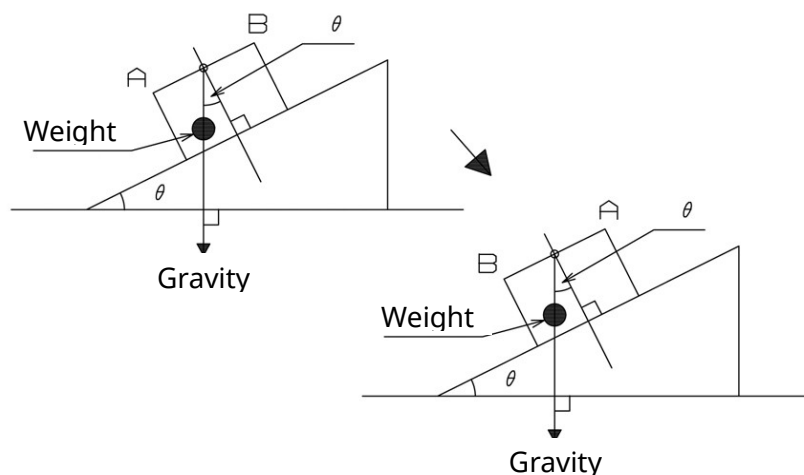

## [ LEVELING A SURFACE ]

Leveling in one direction.

- (1) Place the instrument on the surface, and once the display has stabilized press the 0-Cal Button.
- (2) Rotate the instrument 180° in the same location on the surface, and once the display has stabilized press the 1/2-Cal Button.
- (3) Adjust the tilt of the surface to make the instrument's display read zero.
- (4) Rotate the instrument 180° again to confirm that the reading is zero and the surface is level.  
If it does not read zero after rotating, then repeat steps (1) ~ (4) above.

Note: If there is a large tilt in the roll direction (perpendicular to the measurement axis) there will be some display error and it will be difficult to level the surface. In this case, please also adjust the surface so that the roll direction is also level.

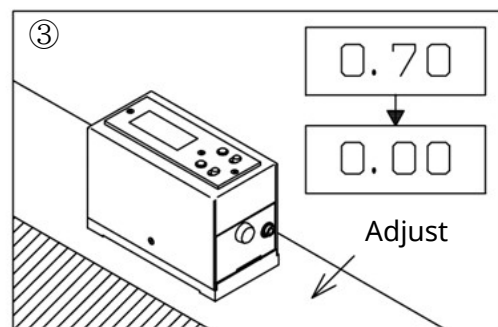
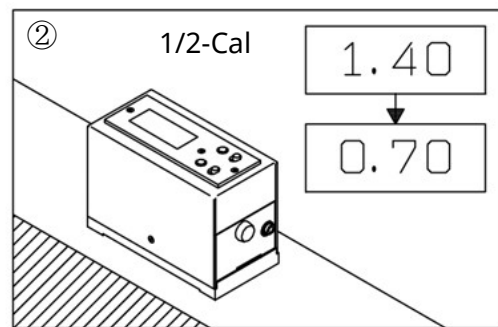
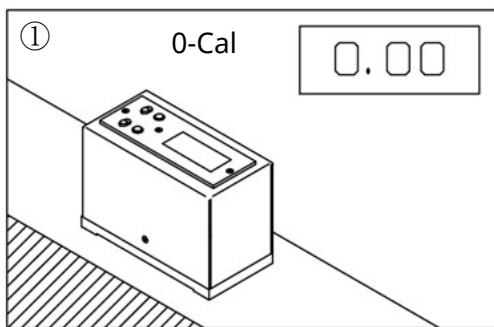

## Leveling in two directions (X, Y direction)

- (1) For one direction (for example the X-direction,) follow the above procedure for "Leveling in one direction."
- (2) Repeat the procedure for the other direction (the Y-direction.)
- (3) When adjusting in one direction, it is possible that the perpendicular direction will be affected and no longer level. It may be necessary to repeat steps (1), (2), several times to bring the two axis into level.  
When the reading is zero for the gauge placed in any position, the surface is level.

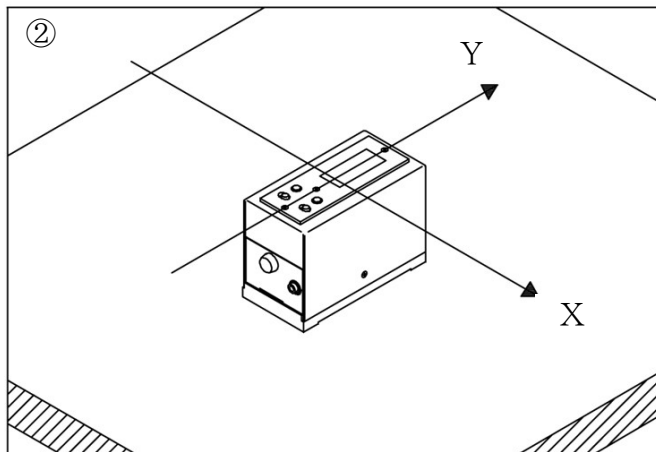
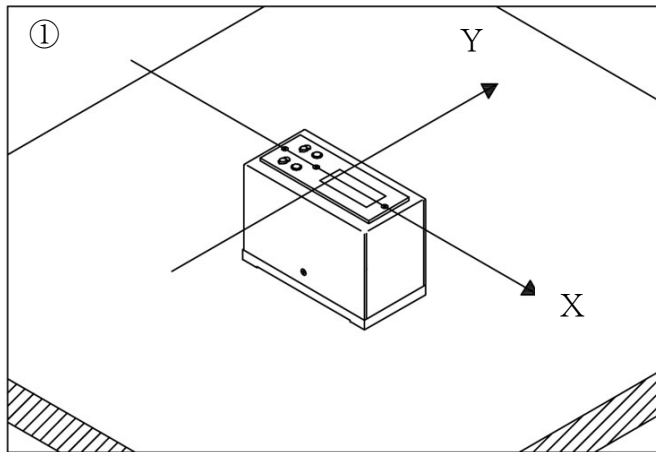

## [ Output Signal ]

The measurement value and units can be read off the Data Out Jack.

The signal is RS-232 compatible so can be connected to any computer or printer with an RS-232 port available.

Use an audio type mini-plug for connecting cable to Data Out Jack.

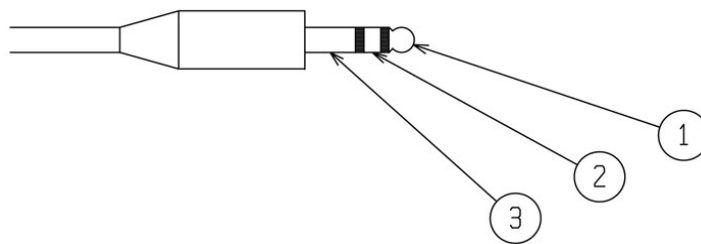

- |                 |                  |
|-----------------|------------------|
| (1) TD (Output) | Transmitted Data |
| (2) CTS (Input) | Clear to Send    |
| (3) GND         | Ground           |

Comm method	Asynchronous
Comm Control	Hardware (CTS controlled)
Baud Rate	1200 bps
Data Length	8 bit
Stop Bits	1
Parity Bit	No
Output signal	±5 V to ±10 V
Input Signal	±3 V to ±15 V

Transmitted data will be 16 characters in each string (Japanese character set.)

The data contents are as follows:

Character 1~14	Measurement data and units, including spaces
Character 15	Carriage Return (CR)
Character 16	Line Feed (LF)

① ② ③ ④ ⑤ ⑥ ⑦ ⑧ ⑨ ⑩ ⑪ ⑫ ⑬ ⑭ ⑮ ⑯	(△symbol = space)
△△△△ 1 . 2 3 △△ mm / M CR LF	Output units of mm/m
△△△ - 1 . 2 3 △△ mm / M CR LF	"
△△△ + Error △△△△△ CR LF	Error Output
△△△ - Error △△△△△ CR LF	"

Signal output is controlled by the CTS signal.  
CTS tells the system when to transmit, or not to transmit data.

If the Function Select Switch is set to "1/2"

- For CTS level "high", measurement data is sent on TD with each data update..
- For CTS level "low", or not connected, measurement data is not sent.
- If CTS is continuously "high", measurement data will be sent continuously.

If the Function Select Switch is set to "OUT"

- For CTS level "high", measurement data is sent on the TD line each time the Output Signal Button (OUT·1/2) is pressed.
- In order to prevent multiple data from being sent, the Output Signal Button will only send out data upon release.
- Data will not be output if Output Signal Button is continuously held down.

Note 1: If CTS goes "low" and stays low for about 3 sec. during the transmission of the 16 character data string, the transmission will be interrupted and the display will show "E1" for about 3 sec. and then return to normal operation.

Note 2: If CTS is "low" when the Output Signal Button is pressed, the display will show "E2" for about 3 sec., and then return to normal.

Note 3: If battery voltage is low, display will blink and data can not be output.

< Timing Chart >

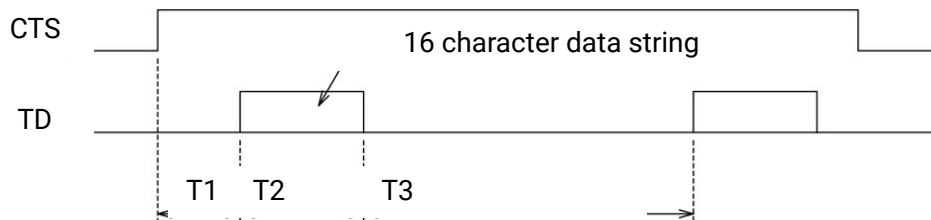

- T1: 1.4msec to ~865msec
- T2: ~136msec
- T3: ~885msec



## [ SHIPPING ]

This is a precision instrument; when carried or shipped, care must be taken to avoid damage. Please be careful not to subject instrument to shock, vibration, or excessive forces when shipped.

### Hand Carrying

Always transport in supplied case.

Transport in upright position and not on side or upside down.

When placing the gauge into the storage case, use care since the outer body is larger than the base and will get stuck.

### Shipping via Truck or Carrier

Please prepare a shipping box with internal size approximately 10cm larger than the storage case in all dimensions.

Place the instrument in the storage case, and place the case in the box with all sides protected with appropriate packing material (such as shredded paper or similar cushioning material.) Pack with enough material to ensure the case will stay centered in the box and will be protected from shock.

The case should be right-side up, and the box marked to insure the box is kept upright during shipping, and not on side or upside down.

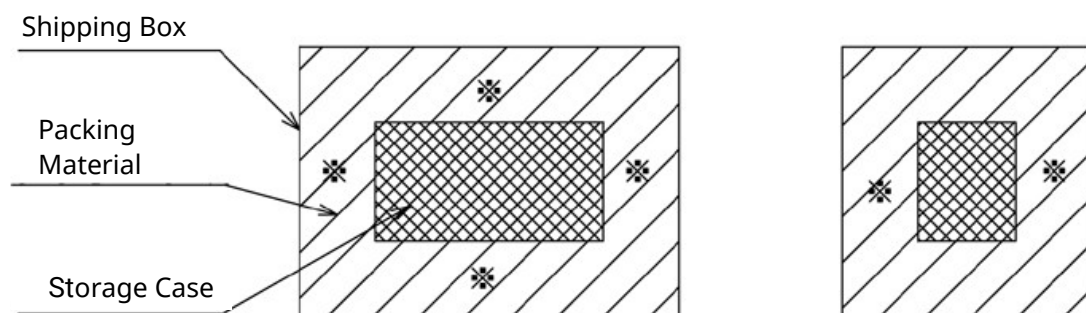

\* Leave room for 5cm of packing material on all six sides

## [ NOTICES ]

- This is a precision instrument, handle with care. While in use and during transport protect from excessive shock, vibration, or excessive force to the main body or to the measuring surface.
- The measuring base is critical component for accurate measurements, use care to protect from corrosion.
- After use, clean any rust or dirt from instrument and apply rust preventive oil to the base before storing in the case.
- If not used for a long period, remove battery.
- Store in cool, dry location out of direct sunlight, and protect from high humidity or severe temperature changes.
- Make sure surface to be measured is free of any dirt or burrs which may cause damage to measuring surface.
- When used in a support capacity for other equipment, it can easily be damaged; please use care to avoid scratches or corrosion.
- Do not modify or use for purpose other than original intended use.

## [ SPECIFICATIONS ]

Model	DL-m3
Measurement Range	±5.00 mm/m
Resolution	0.01mm/m
Operating Temp. range	0~40°C
Accuracy(※1)	[17~23°C] ±0.02 mm/m or, if larger: ±3 %rdg (0 ~ ±2 mm/m) ±4 %rdg (±2 ~ ±5 mm/m) [0~40°C] ±0.02 mm/m or, if larger: ±5 %rdg (0 ~ ±2 mm/m) ±6 %rdg (±2 ~ ±5 mm/m)
Repeatability	Within ±0.01 mm/m
Output Signal	RS-232C compatible
Power	Standard 9V battery (JIS S-006P) (1x)
Continuous Use Time(※2)	Zinc-Carbon battery approx. 35 hours Alkaline battery approx. 70 hours
Dimensions	105 (L) × 50 (W) × 73 (H) mm
Base Dimensions	100 (L) × 50 (W) mm
Weight	0.88kg
Accessories	9V Battery Storage Case Owner's Manual

(※1) % rdg is "percentage of reading"

(※2) Some variation depending on usage conditions.

NIIGATA SEIKI CO., LTD

6-15-22, Tsukanome, Sanjo-city, Niigata 955-0055 JAPAN

TEL: 0256-31-5670