

JUMO dTRON 316



JUMO dTRON 308



JUMO dTRON 308



JUMO dTRON 304

JUMO dTRON 304

JUMO dTRON 308

JUMO dTRON 316

Compact Controller
with program function

B 70.3041.1 Operating Instructions

Contents

1	Preface	3
1.1	Scope of delivery	3
2	Identifying the instrument version	4
3	Mounting	5
3.1	Preparation	5
3.2	Fitting in position, Type 703042/43/44	5
3.3	Fitting in position, Type 703041	5
4	Electrical connection	6
4.1	Connection diagram for Type 703041	6
4.2	Connection diagram for Type 703042/43/44	7
5	Displays and keys	8
6	Operation	9
6.1	Level concept	9
6.2	Level inhibit	10
6.3	Entering values	10
6.4	Entering times	11
6.5	Operation of the fixed-setpoint controller	12
6.6	Operation of the program controller	13
7	Operator level “OPr”	14
8	Parameter level “PArA”	15
9	Configuration level “ConF”	16
9.1	Analog inputs “InP”	16
9.2	Controller “Cntr”	17
9.3	Generator “Pro”	17
9.4	Outputs “OutP”	18
9.5	Display “diSP”	19
10	Autotuning	20
11	Alarms	21

1 Preface



These brief operating instructions only cover those actions that are essential for starting up the controller.

Gray
rastering

The factory settings for the instrument as delivered are shown on a gray background.



The complete configuration options can be found in the comprehensive Operating Manual B 70.3041.0 on the CD, or can be downloaded from <http://www.jumo.net>

1.1 Scope of delivery

- 1 controller
- seal
- mounting brackets
- brief operating instructions
- 1 CD with comprehensive operating instructions and setup program as a demo version

2 Identifying the instrument version

2 Identifying the instrument version

Meaning of the number code on the nameplate:

Basic type	
703041	JUMO dTRON 316, 48mm x 48mm format incl. 1 analog input, 2 relay outputs and 2 binary inputs or 2 logic outputs
703042	JUMO dTRON 308, 48mm x 96mm format (portrait format) incl. 1 analog and 2 binary inputs, 2 relays and 2 logic outputs
703043	JUMO dTRON 308, 96mm x 48mm format (landscape format) incl. 1 analog and 2 binary inputs, 2 relays and 2 logic outputs
703044	JUMO dTRON 304, 96mm x 96mm format incl. 1 analog and 2 binary inputs, 2 relays and 2 logic outputs

Basic type extensions		
1		Basic type 1
	8	Standard, with factory settings
	9	Programming to customer specification
		Logic outputs (2 are available as standard)
	1	0 / 12V
	2	0 / 18V

Type of option slots	
0	not used
1	Analog input 2 (universal)
2	Relay (changeover)
3	2 relays (n.o. make contacts)
4	Analog output
5	2 binary inputs
6	Solid-state relay 1A
7	RS422/485 interface
8	Profibus-DP interface

Supply		
2	3	110 – 240V AC -15/+10%, 48 – 63Hz
2	5	20 – 53V AC/DC, 48 – 63Hz

Extra codes			
0	0	0	none
2	1	4	Math and logic module
2	1	7	Ratio controller
2	1	8	Difference controller
2	1	9	Humidity controller

703041 / 1 8 1 - 0 0 0 - 2 3 / 0 0 0 , 0 0 0

3 Mounting

3.1 Preparation

Type	dTRON	Panel cut-out
703041	316, in 48mm x 48mm format	$45^{+0.6} \times 45^{+0.6}$ mm
703042/43	308, in 48mm x 96mm format (portrait)/(landscape)	$45^{+0.8} \times 92^{+0.8}$ mm
703044	304, in 96mm x 96mm format	$92^{+0.8} \times 92^{+0.8}$ mm

3.2 Fitting in position, Type 703042/43/44

- * Fit the seal that is supplied onto the instrument body.
- * Insert the controller from the front into the panel cut-out.
- * From behind the panel, slide the mounting brackets into the guides on the sides of the housing.
The flat faces of the mounting brackets must lie against the housing.
- * Push the mounting brackets up to the back of the panel, and tighten them evenly with a screwdriver.

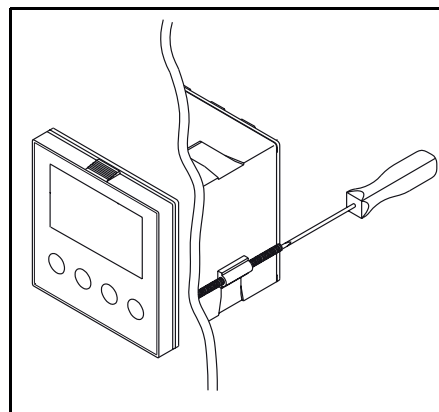

3.3 Fitting in position, Type 703041

- * Fit the seal that is supplied onto the instrument body.
- * Insert the controller from the front into the panel cut-out.
- * From the back of the panel, push the mounting frame onto the instrument body and press it against the back of the panel, compressing the springs, until the latches snap into the notches provided and it is firmly fixed in position.

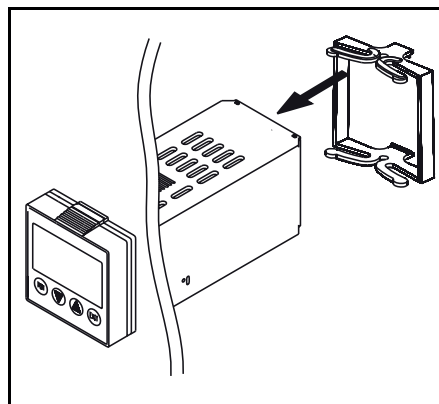

4 Electrical connection

4 Electrical connection

4.1 Connection diagram for Type 703041

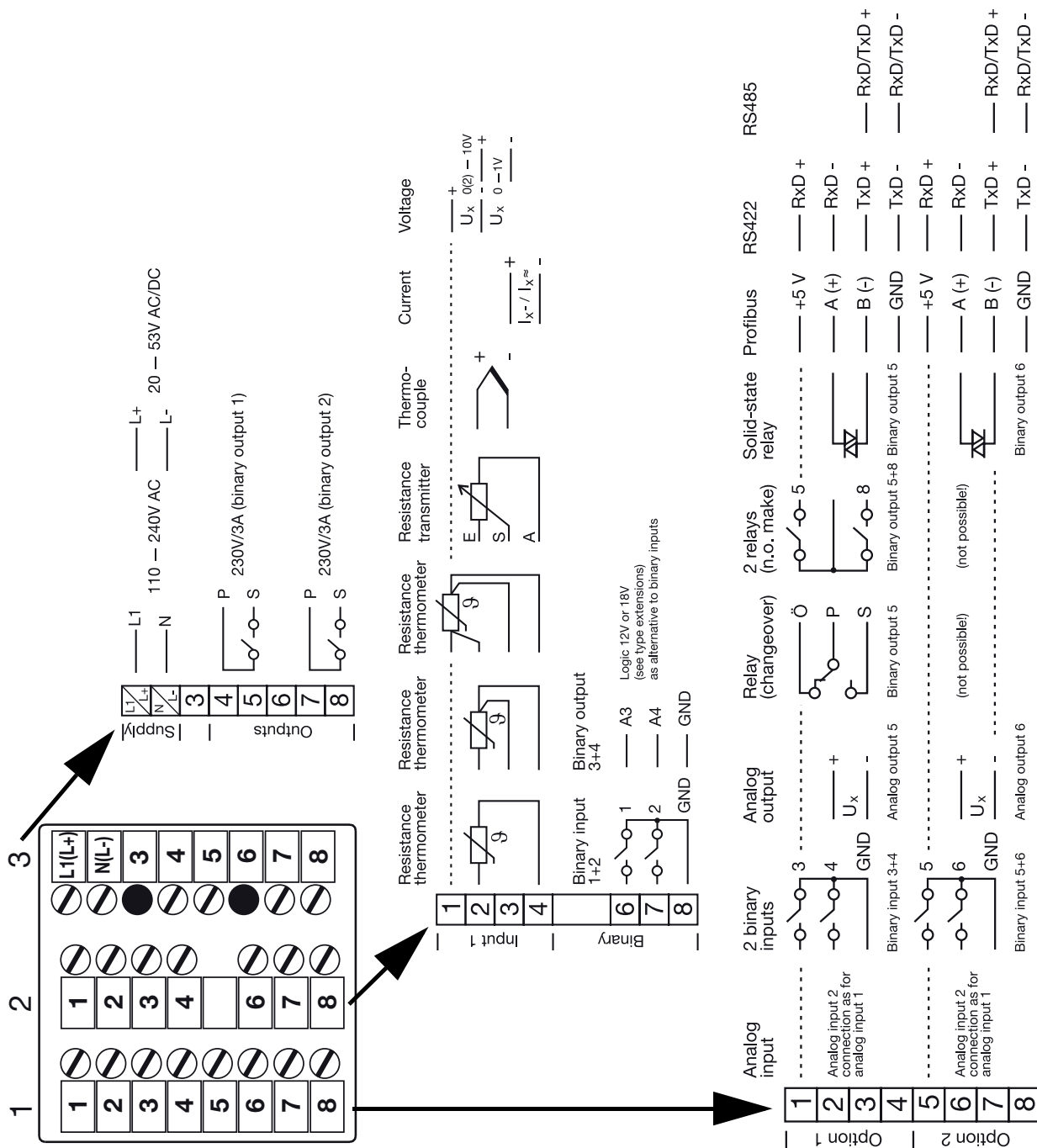

4 Electrical connection

4.2 Connection diagram for Type 703042/43/44

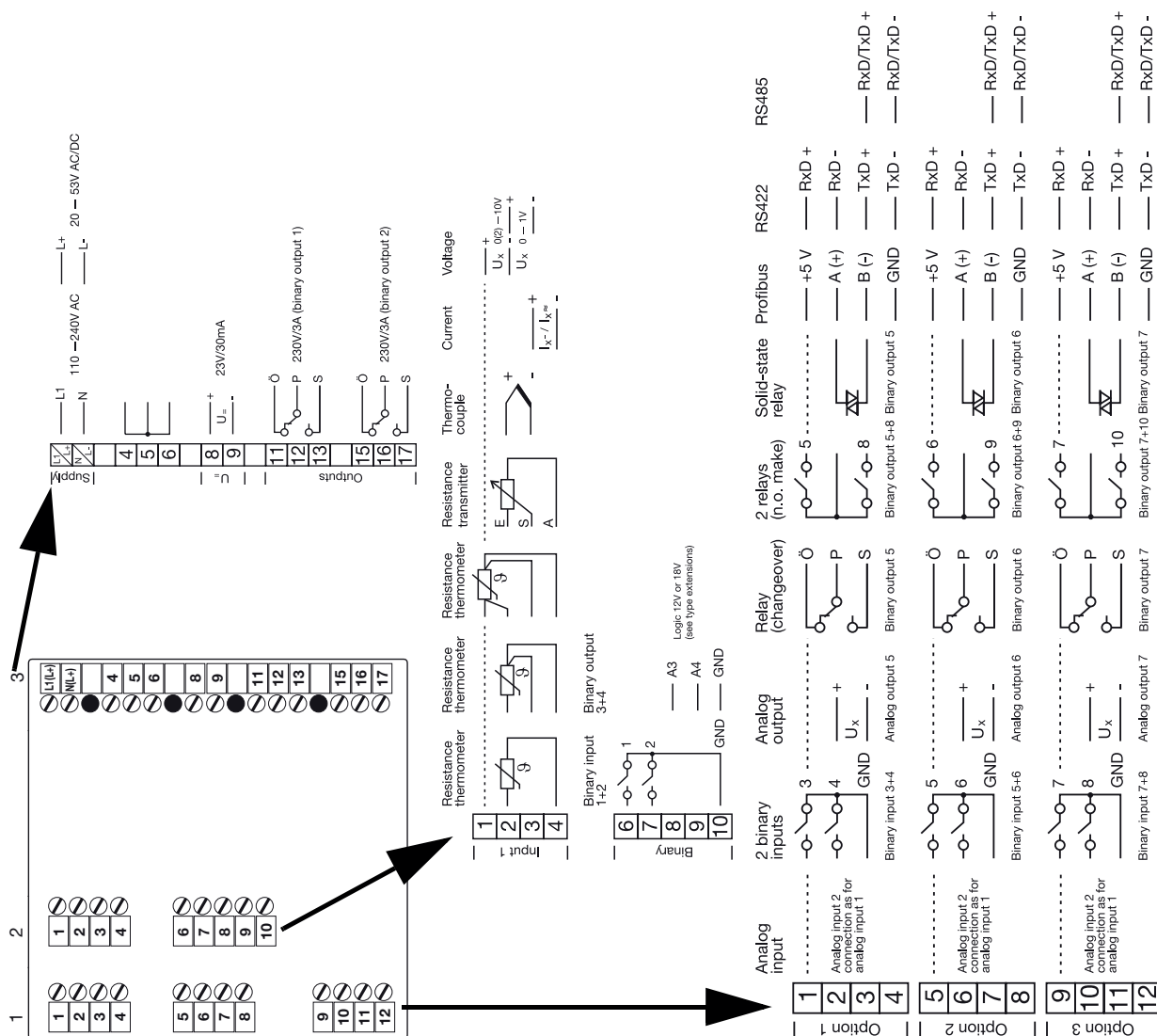

5 Displays and keys

5 Displays and keys

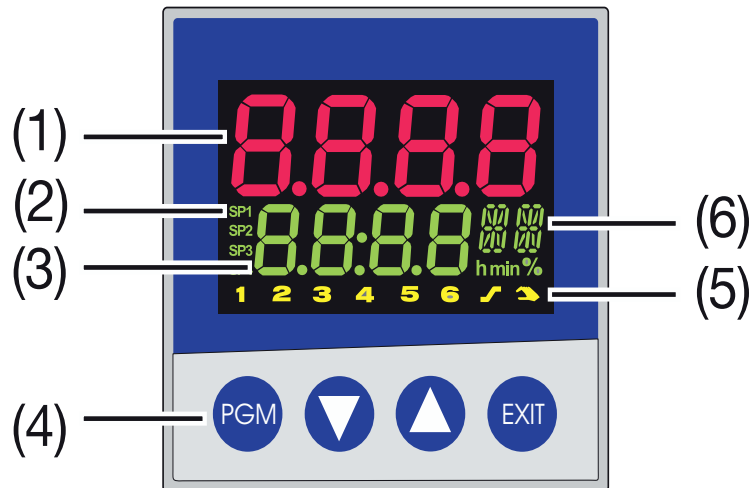

(1)	7-segment display (factory setting: process value) four-digit, red, decimal place is configurable (automatic adjustment on display overflow)
(2)	Active setpoint (factory setting: SP1) SP1, SP2, SP3, SP4 (SP=setpoint); green;
(3)	7-segment display (factory setting: setpoint) four-digit, green, decimal place is configurable; also used for operator prompting (display of parameter and level symbols)
(4)	Keys
(5)	Indication yellow, for - switch status of the binary outputs 1 – 6 - ramp/program function is active - manual operation is active
(6)	16-segment display + dim. units two-digit, green; for the unit °C/°F and symbols for h, min, %

Different values can also be visualized on the display.

⇒ see the comprehensive operating manual on the CD

6 Operation

6.1 Level concept

The diagram below shows the three instrument levels.

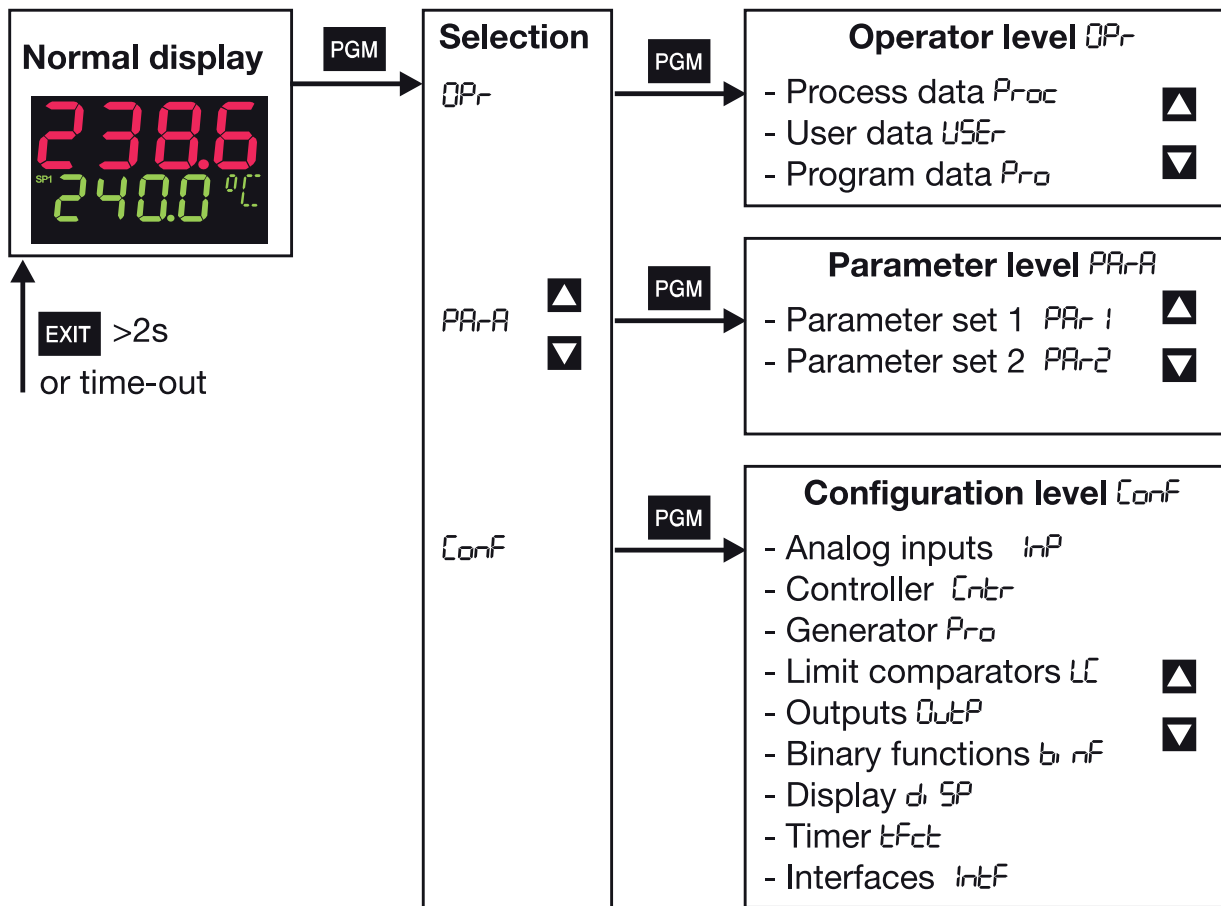

Time-out
 If no key is pressed for 30sec, the instrument returns to normal display.

6 Operation

6.2 Level inhibit

The access to the individual levels can be inhibited by entering a code number.

* Press **PGM** and **▼** simultaneously for >5sec to enter the code.

Code	Operator level	Parameter level	Configuration level
0	enabled	enabled	enabled
1	enabled	enabled	inhibited
2	enabled	inhibited	inhibited
3	inhibited	inhibited	inhibited

* Alter code with **PGM** (display blinks)

* Enter code with **▲** and **▼**

* Return to normal display with **EXIT** or automatically after approx. 30sec

6.3 Entering values

When entries are made within the levels, the parameter symbol is shown in the lower display.

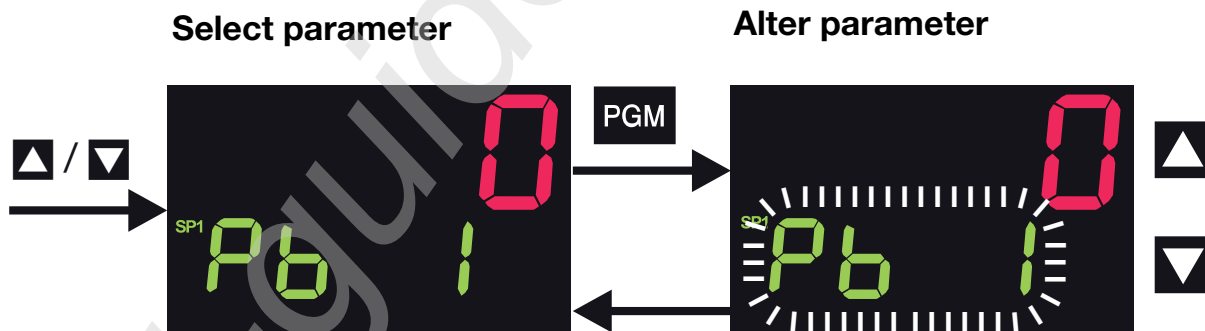

* Select parameter with **▲** or **▼**

* Change to the entry mode with **PGM** (lower display blinks)

* Alter value with **▲** and **▼**

The value alters dynamically with the duration of the key stroke.

* Accept the setting with **PGM** or automatically after 2sec

* or

* Cancel entry with **EXIT**.

The value is not accepted.

6.4 Entering times

When entering times (e.g. time of timer), the time unit is shown in addition.

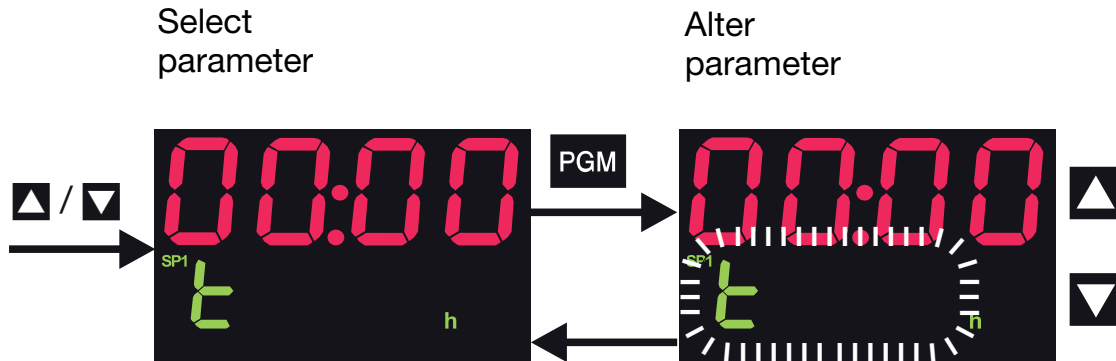

The highest time unit of the display is shown for the unit.

For example, if "h" is shown for the hour, then the time format for the value is hh:mm.

- * Select parameter with ▲ or ▼
 - * Change to the entry mode with PGM (lower display blinks)
 - * Alter value with ▲ and ▼
The value alters dynamically with the duration of the key stroke.
 - * Accept the setting with PGM or automatically after 2sec
- or
- * Cancel entry with EXIT.
The value is not accepted.

6 Operation

6.5 Operation of the fixed-setpoint controller



The fixed-setpoint controller will only function if

- the fixed-setpoint controller function has been configured ($F_{nct} = 0$)

Normal display



Manual mode

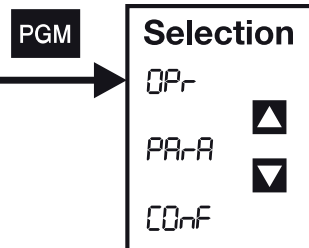

- * Alter the present setpoint with ▲ and ▼

The value is accepted automatically.

The controller output appears in the lower display. The hand symbol and the unit “%” light up in addition.

- * Alter the output with ▲ and ▼

In the case of a modulating controller, the actuator is opened or closed using the keys.

The output entry on a changeover is configurable.

- * Return to the normal display with EXIT (press for more than 2 seconds)

6.6 Operation of the program controller



The program controller will only function if

- the program controller function has been configured ($F_{nct} = 1 \dots 4$)
- the program setpoints ($SPP_1 \dots SPP_8$) and segment times ($t^P_1 \dots t^P_8$) have been entered

Normal display



Alter setpoint

* Alter the present setpoint with ▲ and ▼

The controller controls to the present setpoint.
(The value is accepted automatically after 2 sec.)

Program is running

(the symbol for ramp appears)



Program pause

When the program is paused, the lower display blinks.

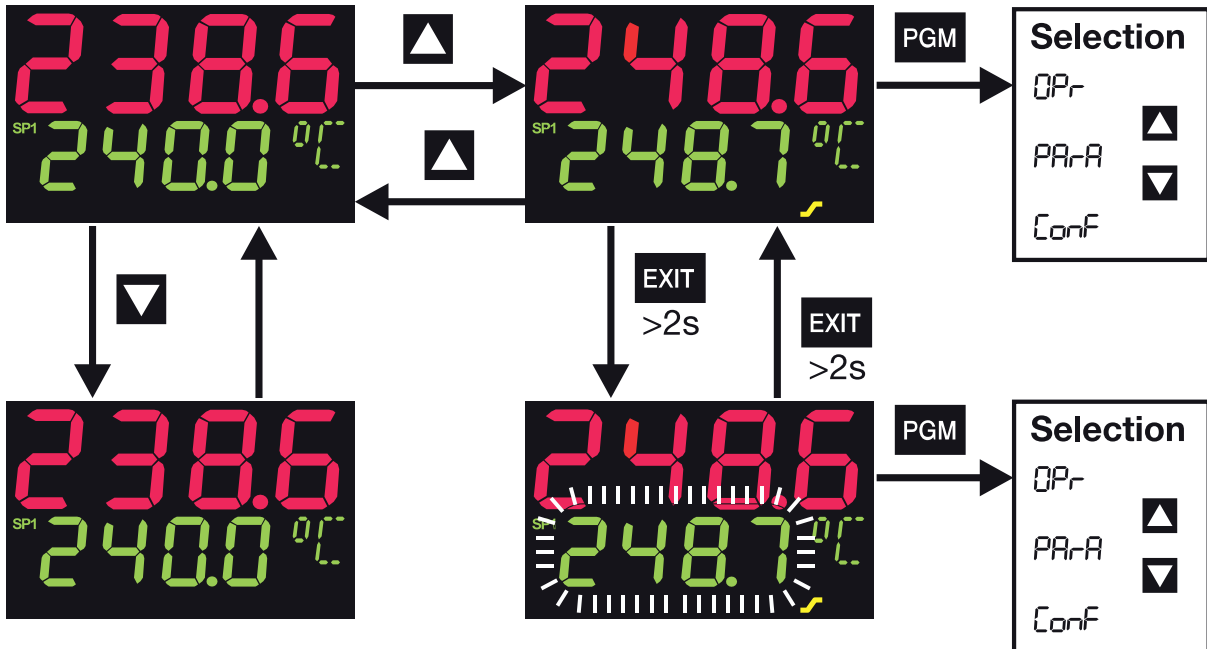

The program is canceled in the event of a power failure.

7 Operator level “OPr”

7 Operator level “OPr”

Process data $PrdC$

Symbol	Meaning
$SP\ 1$	Setpoint 1 (editable)
$SP\ 2$	Setpoint 2 (editable)
$SP\ 3$	Setpoint 3 (editable)
$SP\ 4$	Setpoint 4 (editable)
SP_r	Ramp setpoint (only if configured)
$inP\ 1$	Measurement of analog input 1
$inP\ 2$	Measurement of analog input 2 (only if available)
$F\ 1$	Calculated result of math formula 1 (only if available)
$F\ 2$	Calculated result of math formula 2 (only if available)
Y	Output
t_{run}	Program run time (only with program controller/generator)
t_{res}	Residual program time (only with program controller/generator)
$t\ 1$	Timer: time 1 (only if configured)
$t\ 2$	Timer: time 2 (only if configured)

User data $USER$ (through the setup program only)

Any parameter (up to eight) can be displayed and edited here by using the setup program.

Program data Prd (only with program controller/generator)

A program with up to eight segments is defined here, via the segment setpoints $SPP\ 1...SPP\ 8$ and segment times $tP\ 1...tP\ 8$.

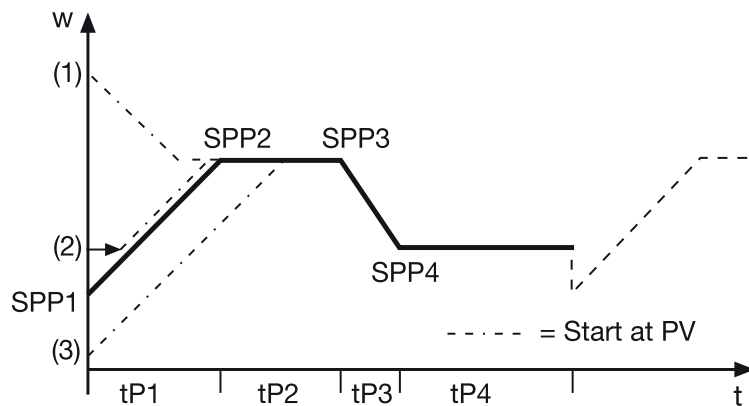

8 Parameter level “PArA”

8 Parameter level “PArA”

Two parameter sets, PAr1 und PAr2, can be stored.

Parameter	Symbol	Value range	Factory setting
Proportional band 1 ^a	Pb 1	0 ... 9999°C/°F	0°C/°F
Proportional band 2 ^b	Pb 2	0 ... 9999°C/°F	0°C/°F
Derivative time ^c	dt	0 ... 9999s	80s
Reset time ^d	rt	0 ... 9999s	350s
Actuator time tt	tt	5 ... 3000s	60s
Cycle time 1	cy 1	0.0 ... 999.9s	20s
Cycle time 2	cy 2	0.0 ... 999.9s	20s
Contact spacing	db	0.0 ... 999.9°C/°F	0°C/°F
Switching differential 1 ^e	HYS 1	0.0 ... 999.9°C/°F	1°C/°F
Switching differential 2	HYS 2	0.0 ... 999.9°C/°F	1°C/°F
Working point	yo	-100 ... +100%	0%
Output limiting (max.)	y1	0 ... 100%	100%
Output limiting (min.)	y2	-100 ... +100%	-100%

- with Pb1/2=0, the controller structure is not effective; depending on the display configuration, these values are shown with the corresponding decimal places
- for controller output 2 (with 3-state controllers)
- with dt=0, the controller has no differential action (e. g. PI controller)
- with rt=0, the controller has no integral action (e. g. PD controller)
- for controllers with Pb1/2=0

9 Configuration level “ConF”

9 Configuration level “ConF”

Depending on the equipment level of the instrument, individual parameters or groups of parameters are switched out of display.

Analog selector

With some parameters, you can choose from a series of analog signals. The list below gives you an overview of the selection options.

- 0 no function
- 1 Analog input 1
- 2 Analog input 2
- 3 Process value (controller)
- 4 Setpoint (controller)
- 5 Ramp end value
- 6 Program setpoint
- 13 Controller output level
- 14 Controller output 1
- 15 Controller output 2

9.1 Analog inputs “InP”

→ *InP1* Analog input 1 →

→ *InP2* Analog input 2 →

Parameter	Symbol	Value range
Sensor type	<i>SEN5</i>	0... 1 ...11
Linearization	<i>Ln</i>	0... 1 ...18
Measurement offset	<i>OFF5</i>	-1999... 0 ...+9999
Display start	<i>SCl</i>	-1999... 0 ...+9999
Display end	<i>SCH</i>	-1999... 100 ...+9999

Factory settings are shown **bold**.

Sensor type	
0 no function	6 Heater current 0 – 50mA AC
1 Resistance thermometer in 3-wire circuit	7 0 – 20mA
2 Resistance thermometer in 2-wire circuit	8 4 – 20mA
3 Resistance thermometer in 4-wire circuit	9 0 – 10V
4 Thermocouple	10 2 – 10V
5 Resistance transmitter	11 0 – 1V

9 Configuration level “Conf”

Linearization	
0 Linear	10 Thermocouple type U
1 Pt100	11 Thermocouple type L
2 Pt500	12 Thermocouple type K
3 Pt1000	13 Thermocouple type S
4 KTY11-6	14 Thermocouple type R
5 Thermocouple type C	15 Thermocouple type B
6 Thermocouple type D	16 Thermocouple type N
7 Thermocouple type E	17 Thermocouple W3Re-W26Re
8 Thermocouple type T	18 customized linearization
9 Thermocouple type J	

→ In 12 Analog input 1 and 2 general →

Parameter	Symbol	Value range
Temperature unit	$Unit$	0 ... 1 (0=°C, 1=°F)
Sampling cycle time	$Cycle$	0 ... 3 (0=50ms; 1=90ms; 2=150ms; 3=250ms)

Factory settings are shown **bold**.

9.2 Controller “Cntr”

Parameter	Symbol	Value range
Controller type	$CType$	0 no function 1 Two-state controller 2, 3 Three-state, modulating controller 4 Continuous controller
Control action	Act	0 ... 1 (0=direct (cooling); 1=inverse (heating))

Factory settings are shown **bold**.

9.3 Generator “Pro”

Parameter	Symbol	Value range
Function	$Funct$	0 Fixed-setpoint controller 1 Ramp function 2 Program controller 3 Program generator 4 Hot-channel controller

Factory settings are shown **bold**.

9 Configuration level “ConF”

9.4 Outputs “OutP”

Numbering of the outputs

Standard: Relay 1 = output 1; relay 2 = output 2; logic output 1 = output 3;
logic output 2 = output 4

Slot	Plug-in board with 1 analog output	Plug-in board with 1 binary output	Plug-in board with 2 binary outputs
Option 1	Output 5	Output 5	Output 5+8
Option 2	Output 6	Output 6	Output 6+9
Option 3	Output 7	Output 7	Output 7+10

→ Analog outputs *OutA* → Output 5 – 7 *Out5...Out7* →

Parameter	Symbol	Value range
Function	<i>Fnct</i>	Analog selector switched off
Signal type	<i>S_i, S_n</i>	0... 2 ... 3 (0 = 0 – 10V; 1 = 2 – 10V; 2 = 0 – 20mA; 3 = 4 – 20mA)
Zero point	<i>OPnt</i>	-1999... 0 ...+9999
End value	<i>End</i>	-1999... 100 ...+9999

Factory settings are shown **bold**.

9 Configuration level “ConF”

→ Binary outputs *OutL* → Output 1 – 10 *Out 1...Out0* →

Function	
0 no function	16 Limit comparator 4
1 Controller output 1	17 Control contact 1
2 Controller output 2	18 Control contact 2
3 - not used	19 Control contact 3
4 - not used	20 Control contact 4
5 Binary input 1	21 Logic formula 1
6 Binary input 2	22 Logic formula 2
7 Binary input 3	23 Timer 1 active
8 Binary input 4	24 Timer 2 active
9 Binary input 5	25 “Program active” signal
10 Binary input 6	26 Program end signal
11 Binary input 7	27 Tolerance limit signal
12 Binary input 8	28 Manual mode on/off
13 Limit comparator 1	29 Binary marker
14 Limit comparator 2	30 Address value (setup)
15 Limit comparator 3	31 always “active”

9.5 Display “diSP”

→

Parameter	Symbol	Value range
Decimal point	<i>dEcP</i>	0 ... 2 (0 = no decimal place; 1 = one; 2 = two)
Brightness	<i>br, B</i>	0 ...5 (0 = bright)

Factory settings are shown **bold**.

10 Autotuning

The autotuning facility can be used to automatically adapt the controller parameters to the process.

The autotuning function determines the controller parameters for a PID controller or, if $dt=0$ is set, for a PI controller in a closed control loop.

* Start with ▲ and ▼ (press simultaneously for >2sec)

“tUnE” is shown blinking in the green display



* Cancel with ▲ and ▼ (press simultaneously).



- The more sluggishly the process responds to setpoint changes, the longer the autotuning procedure will take.
- This involves determining the controller parameters r_t , d_t , Pb_1 , Pb_2 , Cy_1 , Cy_2 , dF and accepting them automatically after the end of tuning.

11 Alarms

Display	Cause	Clear faults check/rectify/replace
- 1999 (blinking!)	Underrange for the value being displayed.	Is the medium to be measured within the range (too hot - too cold?) Check probe for probe break/short-circuit. Check the probe connection and the terminals. Check the cable.
9999 (blinking!)	Overrange for the value being displayed.	
All displays are on; lower 7-segment display is blinking	Watchdog or power-on triggers initialization (reset).	Replace controller if the initialization takes longer than 5 sec.
Pr-0F	PROFIBUS error	Can be suppressed by setting the PROFIBUS address to "0.
0PŁ	Hardware configuration error	Check which option boards are installed in the slots.

Overrange/underrange covers the following events:

- probe break/short-circuit
- measurement is outside the controllable range for the probe connected
- display overflow

Displaying the software version

* Display version with **PGM** and **▲** (press simultaneously).

11 Alarms



JUMO GmbH & Co. KG

Street address:

Moltkestraße 13 - 31
36039 Fulda, Germany

Delivery address:

Mackenrodtstraße 14
36039 Fulda, Germany

Postal address:

36035 Fulda, Germany

Phone: +49 661 6003-0
Fax: +49 661 6003-607
e-mail: mail@jumo.net
Internet: www.jumo.net

JUMO Instrument Co. Ltd.

JUMO House
Temple Bank, Riverway
Harlow, Essex CM20 2TT, UK
Phone: +44 1279 635533
Fax: +44 1279 635262
e-mail: sales@jumo.co.uk
Internet: www.jumo.co.uk

JUMO PROCESS CONTROL INC.

885 Fox Chase, Suite 103
Coatesville PA 19320, USA
Phone: 610-380-8002
1-800-554-JUMO
Fax: 610-380-8009
e-mail: info@JumoUSA.com
Internet: www.JumoUSA.com